

Overview

PRIME RGB 30000 is a full-color laser projector that could meet your requirement for any Mega-scale outdoor laser shows and installations. Its high power and extreme sharp beam enables it the capability to take care of any job where power density is the most needed.



Front Panel



Rear Panel



Front 45°

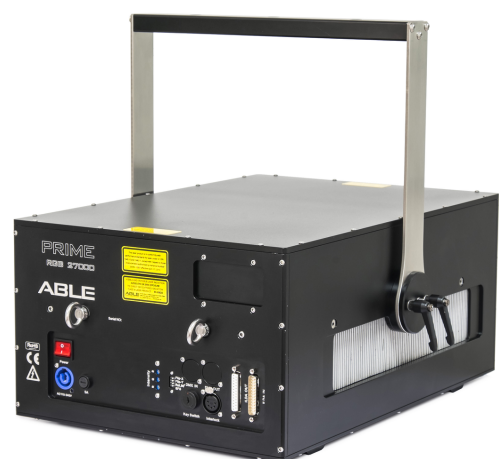

Rear 45°

PRIME RGB 30000 has 3 sub-models to fit the needs of different power range and budget.

Specifications

Spec Power @ Light Source

	<u>PRIME RGB 30000</u>	<u>PRIME RGB 27000</u>	<u>PRIME RGB 24000</u>	
R:	6660 mW@637nm	6660 mW@637nm	5550 mW@637nm	Single-Mode Direct-Inject diodes
G:	8000 mW@520nm	8000 mW@520nm	7000 mW@520nm	Multi-Mode Direct-Inject diodes
B:	16000 mW@445nm	12800 mW@445nm	11200 mW@445nm	Multi-Mode Direct-Inject diodes

Total Output @ Projector window

<u>PRIME RGB 30000</u>	<u>PRIME RGB 27000</u>	<u>PRIME RGB 24000</u>
23000 - 24000 mW	21000 - 22000 mW	17500 - 18500 mW

Beam Profile

Beam Diameter (Projector Window): 5.5 mm * 6.2 mm

Divergence (Full angle): <1.0 mrad

Modulation : Analog 50KHZ

Laser Class : Class IV



Dichro access through side panel for easy beam re-alignment

Standard scanner

Galvo : 35K (EMS 8000 40K upon request)

Scan Angle : 60° Max (54° on EMS 8000)

Interfaces & Controls

Control :	ILDA in (Differential) , ILDA out
Safety :	Key Switch , Scan-Fail-Safe Switch
Remote Interlock :	5 pins XLR
Scan Image Invert :	Invert – X , Invert – Y
Color adjustment :	Intensity R, G, B (0-100%)
Mains :	Neutrik PowerCon®

Optional Components

Embedded Controller:	Pangolin FB4 (upon request)
Scanner:	EMS 8000 40K, 54° Max Angle

Thermal Control

Cooling :	Active Cooling/heating by TEC Peltier Elements
Ventilation :	60mm Low noise thermal-controlled fan * 5

Electric

Operating Voltage :	AC 110V-240V
Power Consumption:	650W Max

Physical

L * W * H :	470mm * 326mm * 215mm (Without Yoke)
Weight :	30 kg
Housing Materials :	Black Anodized Aluminum
IP grade :	IP54
Packaging :	Flight case / Peli Case

PRODUCT INFORMATION

PRIME RGB 30000

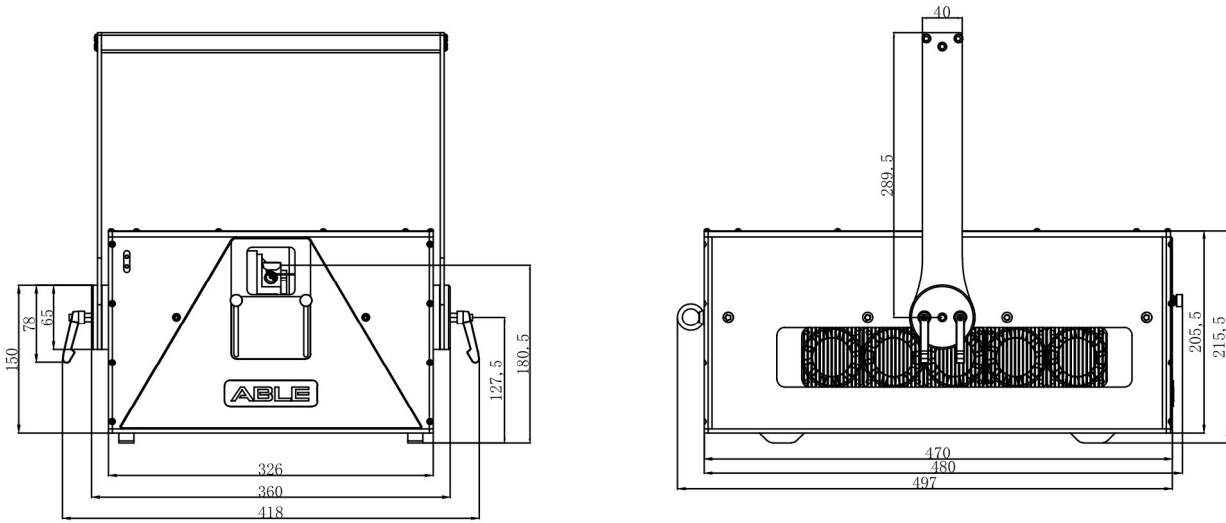

Compliance

Compliance FDA/CDRH, CE, RoHS

Warranty

Warranty 24 months parts and labor

* The above specifications subject to change without prior notice